

### PNP Silicon Epitaxial Planar Transistor

for high current switching, interface circuit and driver circuit application.

#### Feature

- With built-in bias resistor
- Simplify circuit design
- Reduce a quantity of parts and manufacturing process

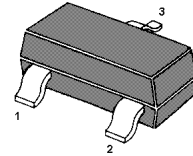
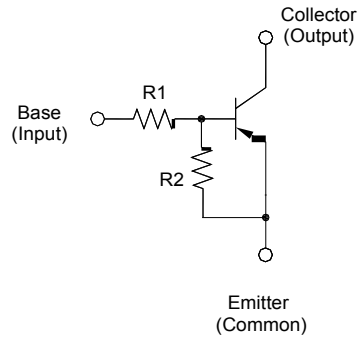

1. Base 2. Emitter 3. Collector  
SOT-23 Plastic Package

#### Resistor Values

Type	R1 (KΩ)	R2 (KΩ)
MMBTRA221SS	1	1
MMBTRA222SS	2.2	2.2
MMBTRA223SS	4.7	4.7
MMBTRA224SS	10	10
MMBTRA225SS	1	10
MMBTRA226SS	2.2	10

#### Absolute Maximum Ratings (T<sub>a</sub> = 25 °C)

Parameter	Symbol	Value	Unit
Output Voltage	-V <sub>O</sub>	50	V
Input Voltage	-V <sub>I</sub>	10, -10	V
		12, -10	
		20, -10	
		30, -10	
		10, -5	
		12, -6	
Output Current	-I <sub>O</sub>	300	mA
Total Power Dissipation	P <sub>tot</sub>	200	mW
Junction Temperature	T <sub>J</sub>	150	°C
Storage Temperature Range	T <sub>stg</sub>	- 55 to + 150	°C



### Characteristics at $T_a = 25\text{ }^\circ\text{C}$

Parameter	Symbol	Min.	Typ.	Max.	Unit
DC Current Gain at $-V_o = 5\text{ V}$ , $-I_o = 50\text{ mA}$	MMBTRA221SS	33	-	-	-
	MMBTRA222SS	39	-	-	-
	MMBTRA223SS	47	-	-	-
	MMBTRA224SS	56	-	-	-
	MMBTRA225SS	56	-	-	-
	MMBTRA226SS	56	-	-	-
Output Cutoff Current at $-V_o = 30\text{ V}$	$-I_{O(OFF)}$	-	-	10	$\mu\text{A}$
Input Current at $-V_i = 5\text{ V}$	MMBTRA221SS	-	-	7.2	mA
	MMBTRA222SS	-	-	3.8	
	MMBTRA223SS	-	-	1.8	
	MMBTRA224SS	-	-	0.88	
	MMBTRA225SS	-	-	7.2	
	MMBTRA226SS	-	-	3.6	
Output Voltage at $-I_o = 10\text{ mA}$ , $-I_i = 0.5\text{ mA}$	$-V_{O(ON)}$	-	-	0.6	V
Input Voltage (ON) at $-V_o = 0.3\text{ V}$ , $-I_o = 20\text{ mA}$	MMBTRA221SS	-	-	3	V
	MMBTRA222SS	-	-	3	
	MMBTRA223SS	-	-	3	
	MMBTRA224SS	-	-	3	
	MMBTRA225SS	-	-	3	
	MMBTRA226SS	-	-	2	
Input Voltage (OFF) at $-V_o = 5\text{ V}$ , $-I_o = 0.1\text{ mA}$	MMBTRA221SS~224SS	$-V_{I(OFF)}$	0.5	-	V
	MMBTRA225SS~226SS		0.3	-	
Transition Frequency at $-V_o = 10\text{ V}$ , $-I_o = 5\text{ mA}$ , $f = 100\text{ MHz}$	$f_T$ <sup>1)</sup>	-	200	-	MHz

1) Characteristic of transistor only.



**CHINA BASE**  
INTERNATIONAL

**SOT-23**



**MMBTRA221SS-MMBTRA226SS**

www.china-base.com.hk

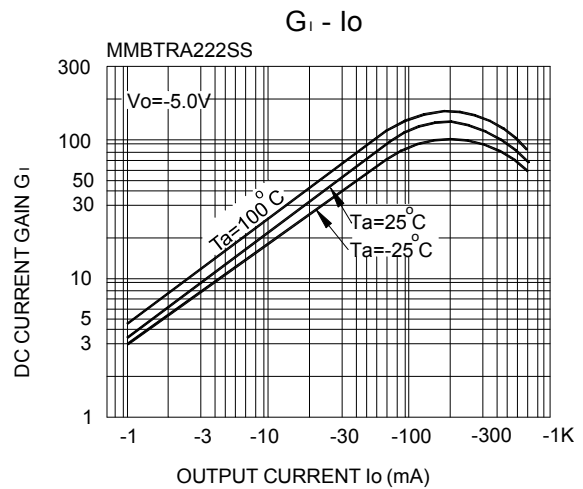
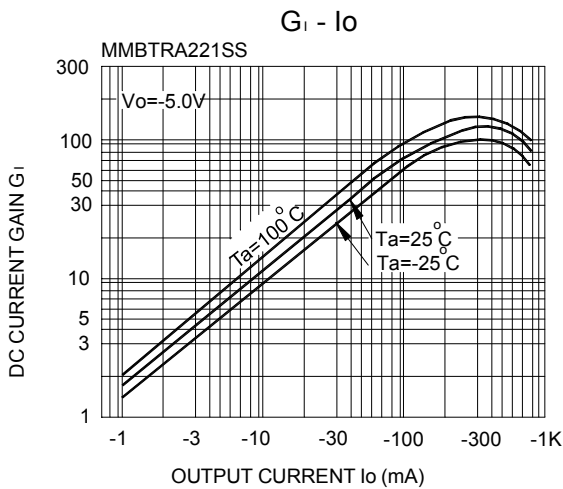
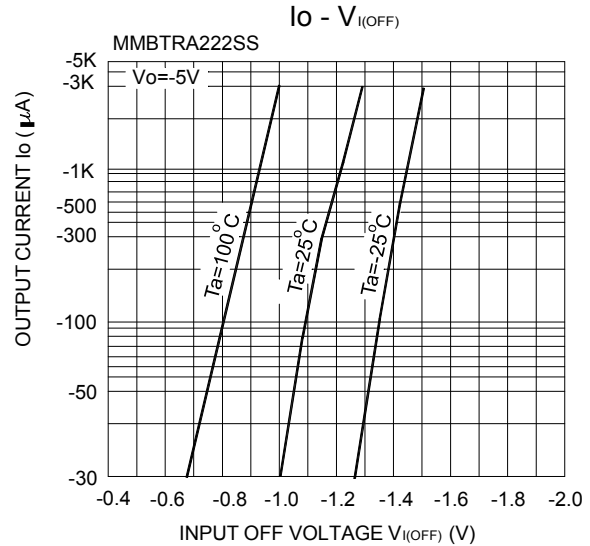
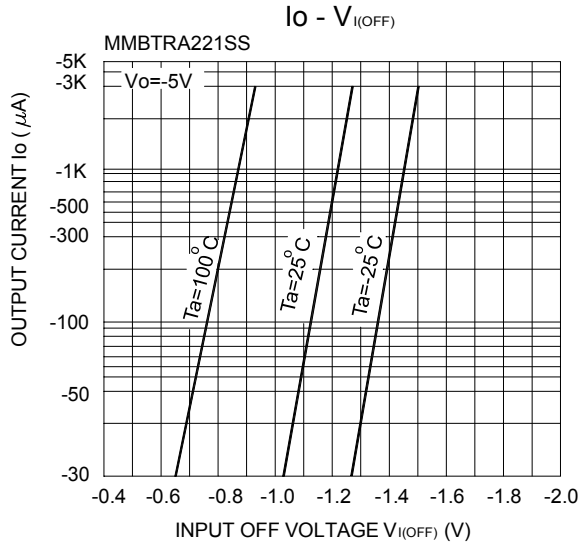
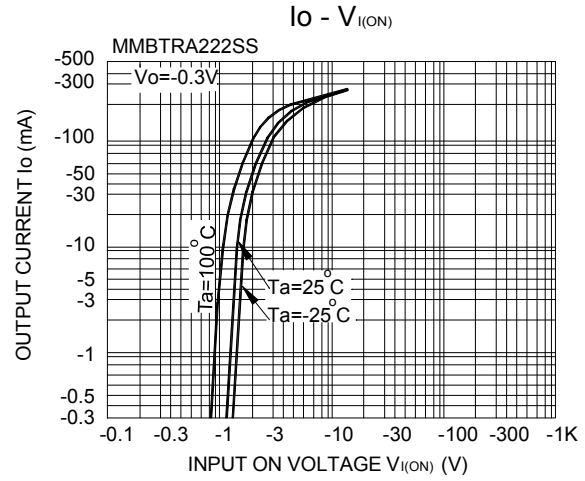
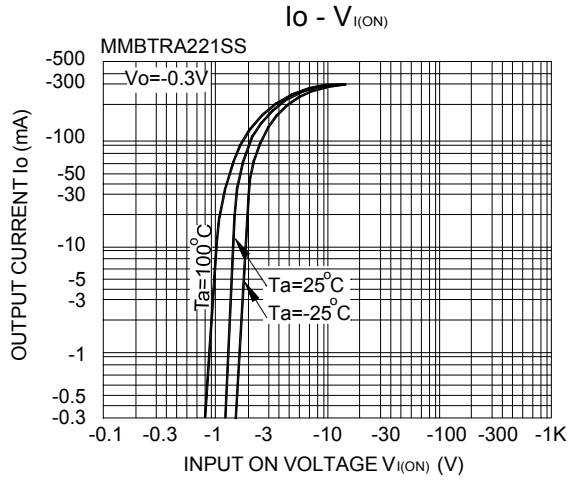



**CHINA BASE**  
INTERNATIONAL

**SOT-23**



**MMBTRA221SS-MMBTRA226SS**

www.china-base.com.hk

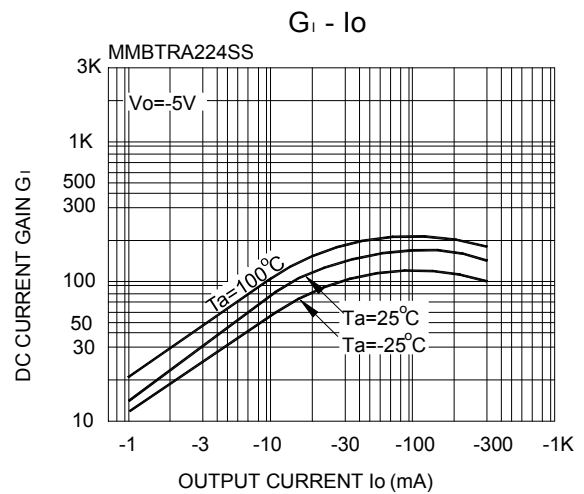
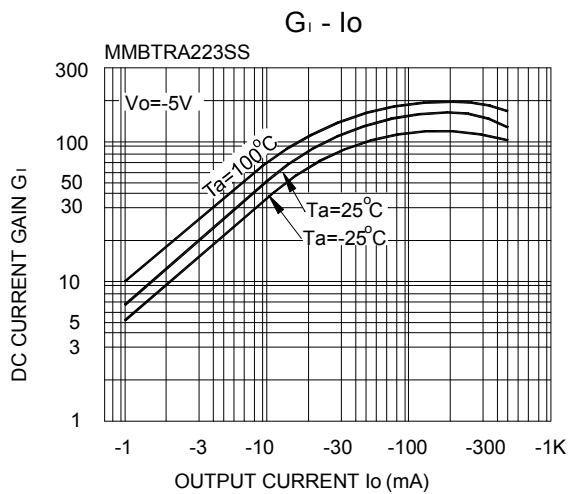
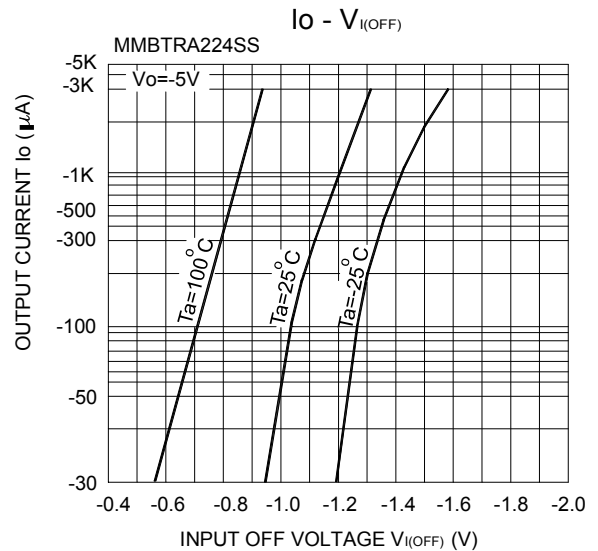
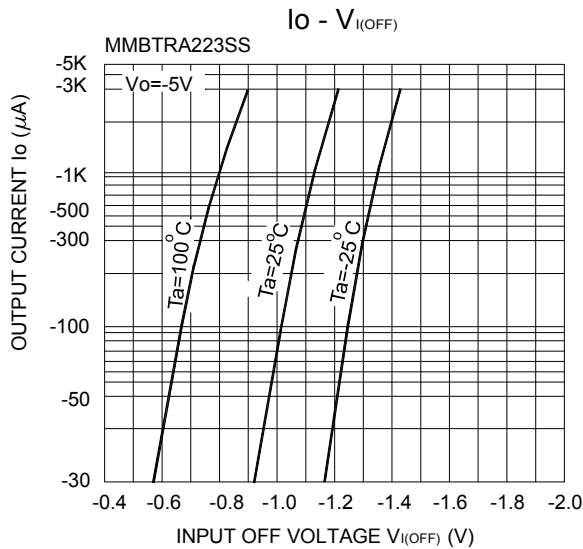
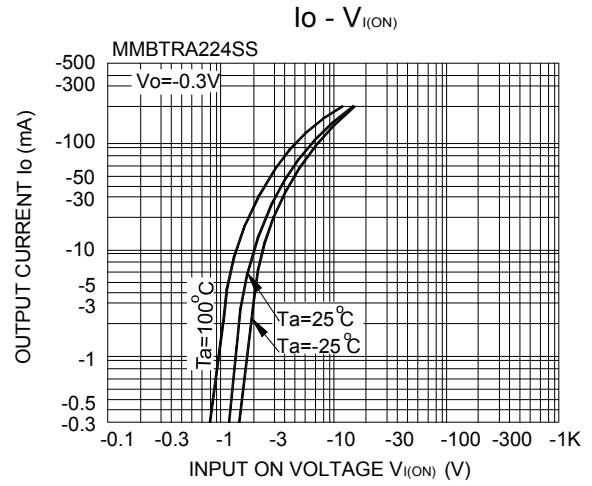
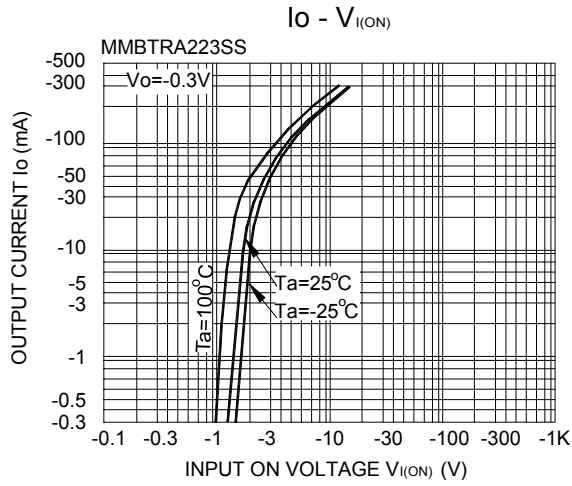



**CHINA BASE**  
INTERNATIONAL

# SOT-23



# MMBTRA221SS-MMBTRA226SS

www.china-base.com.hk

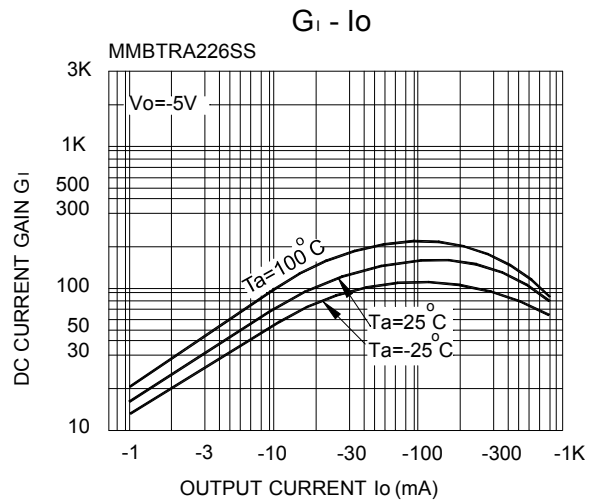
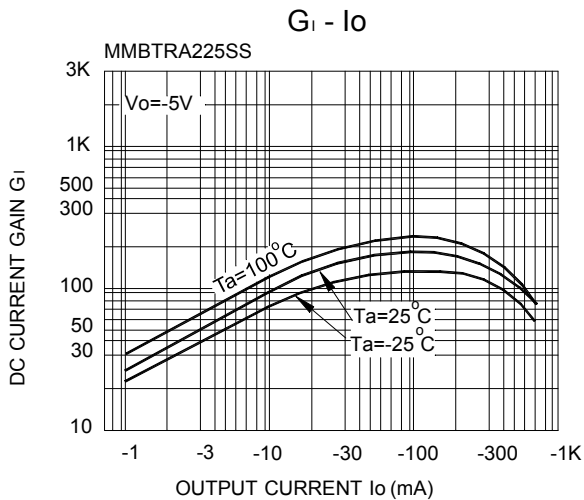
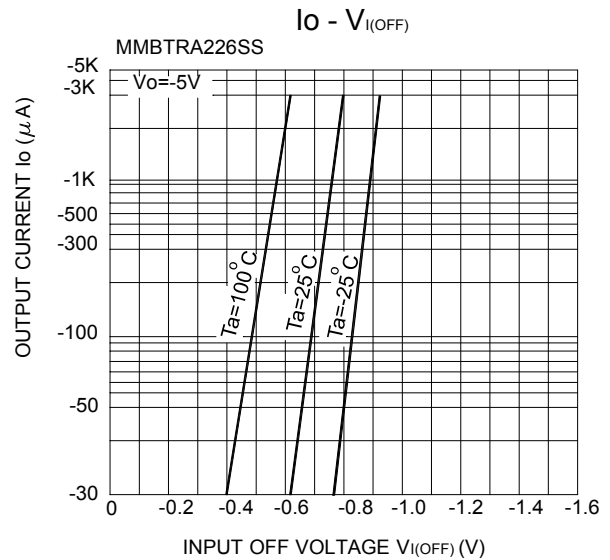
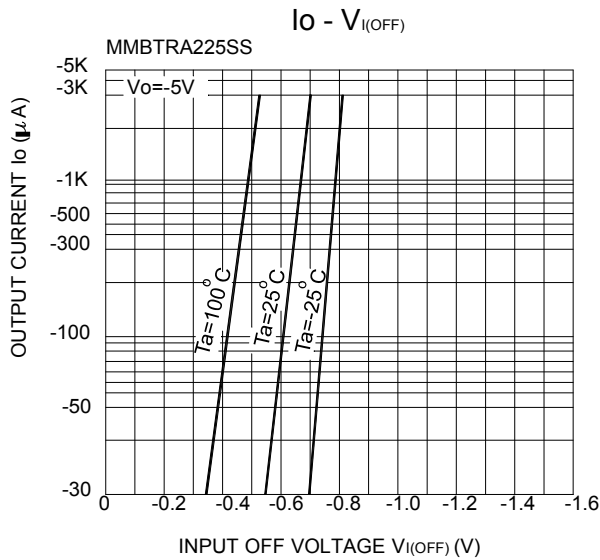
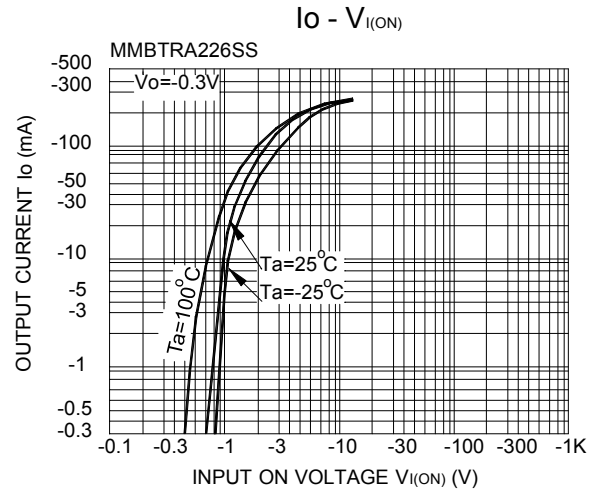
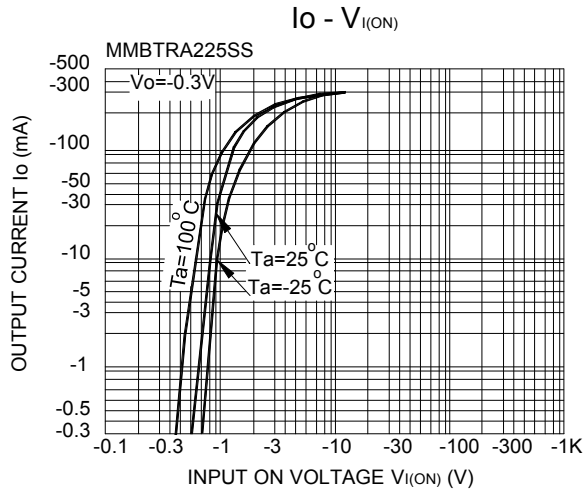



### PACKAGE OUTLINE

Plastic surface mounted package; 3 leads

SOT-23

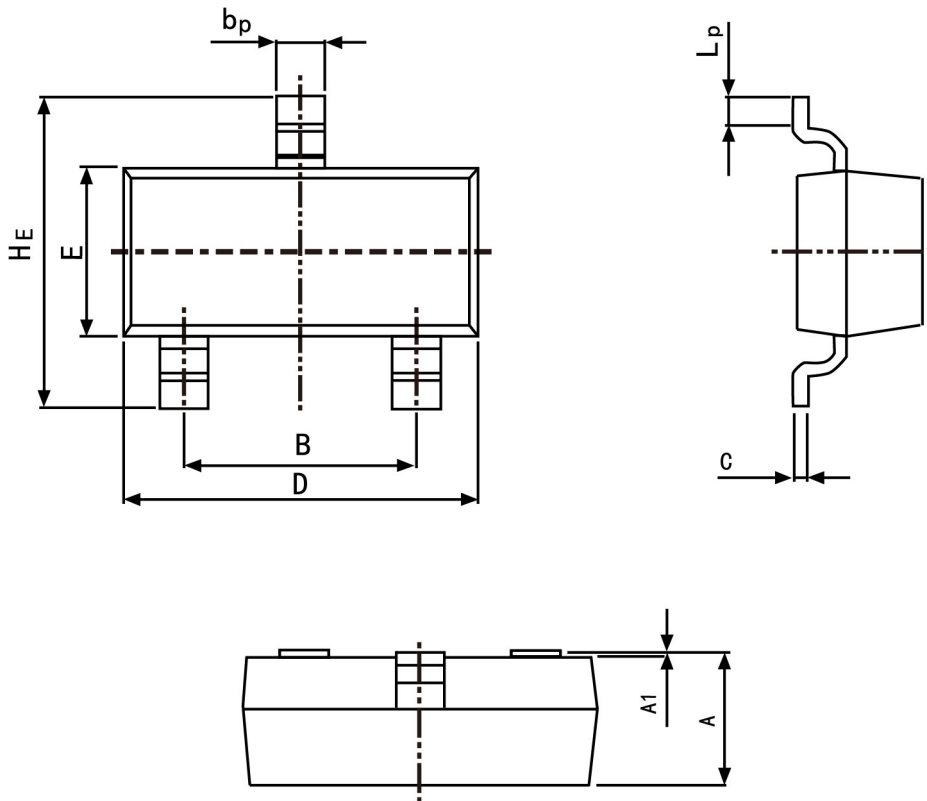

Symbol	Dimension in Millimeters	
	Min	Max
A	0.95	1.40
B	1.78	2.04
$b_p$	0.35	0.50
C	0.08	0.19
D	2.70	3.10
E	1.20	1.65
HE	2.20	3.00
$A_1$	0.100	0.013
$L_p$	0.20	0.50